

### Phase Control Dual Diode Module 985 Amperes/Up to 5000 Volts

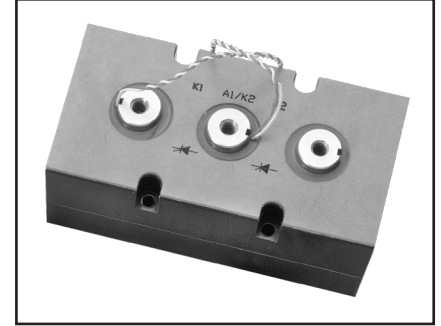
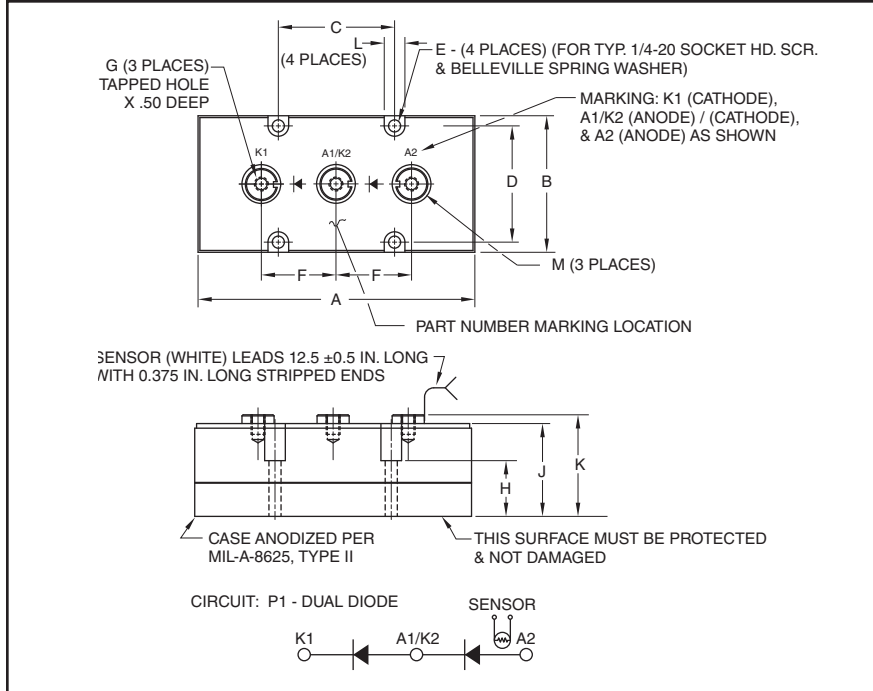

#### Description:

Powerex Dual Diode POW-R-BRIK™ Modules are designed for medium and high current applications. POW-R-BRIK™ Modules feature an electrically isolated package that simplifies system packaging, installation and cooling. POW-R-BRIK™ Modules utilize Compression Bonded Encapsulation (CBE) mounting and double side cooling of the semiconductor elements. The P1ZAA uses 67mm diodes. Other standard circuit configurations include SCR/SCR, SCR/Diode and Diode/SCR. Additional circuit configurations, e.g. single element, common cathode, common anode, and special element types, e.g. fast switch SCRs, fast recovery diodes are available.

#### Features:

- High Inrush Current Capability
- Electrically Isolated Packaging
- Internal Copper Contacting
- Gold Element Contacting
- Compression Bonded Elements
- Internal Temperature Sensor
- Two Sided Cooling
- High Thermal Mass for Increased Surge and Overload Capability

#### Applications:

- DC Motor Controls
- Transportation Systems
- Battery Supplies
- Bridge Circuits
- Resistance Welding Controls
- Mining Power Centers

#### Outline Drawing and Circuit Diagram

Dimensions	Inches	Millimeters
A	8.50	215.9
B	4.33	109.98
C	3.15	80.01
D	3.78	96.01
E	0.328 Dia.	8.33 Dia.
F	2.34±0.03	59.4±0.8
G	7/16-14 UNC-2B	
H	2.14	54.36
J	3.15	80.01
K	3.38	85.85
L	0.56	14.22
M	1.12	28.45

All dimensions are 0.02 unless otherwise specified.

#### Voltage Code: Wxx

Type	Voltage Code	Voltage Volts
P1ZAA	W36	3600
	W42	4200
	W45	4500
	W50	5000

#### Ordering Information:

Select the complete thirteen digit module part number from the Element, Special and Voltage Tables below.  
Example: P1 ZAA DDA 00 W50 is a Dual Diode POW-R-BRIK™ Module with 67mm elements, Rated 985 Ampere, Standard Thermistor and rated at 5000 Volts.

#### Element Code: DDA

#### Special Code: 00

00 - Standard Thermistor  
XT - No Thermistor  
AA-ZZ - Special customer unique specifications.

Note: For detailed application information on thermistor circuit refer to Rectifier/Thyristor Module Data Book, Page 3.



Powerex, Inc., 173 Pavilion Lane, Youngwood, Pennsylvania 15697 (724) 925-7272 www.pwr.com

**P1ZAA POW-R-BRIK**  
**Phase Control Dual Diode Module**  
 985 Amperes/Up to 5000 Volts

**Absolute Maximum Ratings,  $T_j = 25^\circ\text{C}$  unless otherwise specified**

Ratings	Symbol	P1ZAA	Units
Junction Temperature	$T_j$	-40 to 150	$^\circ\text{C}$
Storage Temperature	$T_{stg}$	-40 to 125	$^\circ\text{C}$
Repetitive Peak Forward and Reverse Blocking Voltage	$V_{RRM}$	Up to 5000	Volts
Non-Repetitive Reverse Blocking Voltage	$V_{RSM}$	$V_{RRM} + 100$	Volts
RMS Forward Current	$I_T(\text{RMS})$	1320	Amperes
Average Forward Current (180° Conduction, $T_C = 80^\circ\text{C}$ )	$I_T(\text{avg})$	985	Amperes
Peak Half-Cycle Surge Current (8.3 ms, 100% $V_{RRM}$ Reapplied)	$I_{TSM}$	24,000	Amperes
Peak Half-Cycle Surge Current (10.0 ms, 100% $V_{RRM}$ Reapplied)	$I_{TSM}$	21,800	Amperes
$I^2t$ for Fusing for One Cycle (8.3 ms, 100% $V_{RRM}$ Reapplied)	$I^2t$	$2.40 \times 10^6$	$\text{A}^2\text{-sec}$
$I^2t$ for Fusing for One Cycle (10.0 ms, 100% $V_{RRM}$ Reapplied)	$I^2t$	$2.37 \times 10^6$	$\text{A}^2\text{-sec}$
Maximum Electrical Terminal Mounting Torque	—	30	ft-lbs
Maximum Mounting Bolt Torque	—	12	ft-lbs
Module Weight, Typical	—	19	lbs
		8.6	Kg
Isolation Voltage	$V_{ISO}$	5000	$V_{rms}$

**Electrical Characteristics,  $T_j = 25^\circ\text{C}$  unless otherwise specified**

Characteristics	Symbol	Test Conditions	Max.	Units
Repetitive Peak Forward and Reverse Leakage Current	$I_{DRM}/I_{RRM}$	$T_j = 150^\circ\text{C}$	150	mA
Peak On-State Voltage	$V_{TM}$	$T_j = 25^\circ\text{C}$ , $I_{TM} = 3000\text{A}$	1.45	Volts
Threshold Voltage, Low-Level	$V_{(TO)1}$	$T_j = 150^\circ\text{C}$ , $I = 15\% I_T(\text{avg})$ to $\pi I_T(\text{avg})$	0.964	Volts
Slope Resistance, Low-Level	$r_{T1}$		0.207	m $\Omega$
Threshold Voltage, High-Level	$V_{(TO)2}$	$T_j = 150^\circ\text{C}$ , $I = 15\% \pi I_T(\text{avg})$ to $I_{TSM}$	1.77	Volts
Slope Resistance, High-Level	$r_{T2}$		0.125	m $\Omega$
$V_{TM}$ Coefficients, Low-Level		$T_j = 150^\circ\text{C}$ , $I = 15\% I_T(\text{avg})$ to $\pi I_T(\text{avg})$	A = 1.983 B = -0.254 C = $6.38 \times 10^{-5}$ D = 0.02697	

**Thermal and Mechanical Characteristics,  $T_j = 25^\circ\text{C}$  unless otherwise specified**

Characteristics	Symbol	Test Conditions	Max.	Units
Thermal Resistance, Junction to Case	$R_{th(j-c)Q}$	Per Module, Both Conducting	0.024	$^\circ\text{C}/\text{W}$
Thermal Resistance, Junction to Case	$R_{th(j-c)D}$	Per Diode, Both Conducting	0.048	$^\circ\text{C}/\text{W}$
Thermal Resistance, Case to Sink (Lubricated)	$R_{th(c-s)}$	Per Module	0.007	$^\circ\text{C}/\text{W}$