

Description:

The TLI-Series has been designed for three level (neutral point clamped) topologies in applications requiring high efficiency operation and improved output waveform quality. They also provide significant benefits in applications where low output noise using small filter components is required or where long motor leads create Standing Wave Ratio (SWR) voltage surge issues.

Features:

- Smaller Output Voltage Steps Reducing Surge Voltage
- Low Output Ripple Current
- Lower Modulation Frequency With Same Quality Output Waveform

Applications:

- Three Level Inverter Topologies
- Solar Power Inverters
- High Efficiency UPS
- Long Motor Lead Applications

Ordering Information:

Example: Select the complete module number you desire from the table - i.e. CM75YE13-12F is a 600V (V_{CES}), 75 Ampere TLI-Series IGBT Power Module.

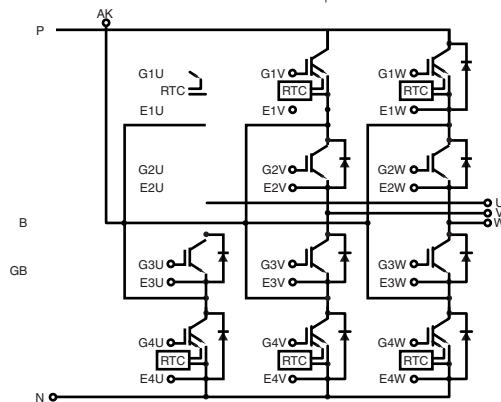

Dim.	Inches	Millimeters
A	4.92	125.0
B	4.47	113.5
C	0.89+0.04/-0.02	22.5+1.0/-0.5
D	3.9±0.01	98.5±0.25
E	1.01	25.75
F	0.93	23.5
G	1.03	26.25
H	0.22	5.50
J	0.38	9.75
K	0.39	10.0
L	0.49	12.5
M	0.61	15.5
N	0.54	13.75
P	1.18	30.0
Q	2.4	61.0

Dim.	Inches	Millimeters
R	0.47	12.0
S	0.75	19.0
T	0.30	7.5
U	4.33±0.01	110.0±0.25
V	0.94	24.0
W	M5 Metric	M5
X	0.08	2.0
Y	0.22 Dia.	5.5 Dia.
Z	0.16	4.0
AA	0.34	8.7
AB	0.26	6.5
AC	0.10	2.5
AD	XHP-11 Housing	
AE	XHP-12 Housing	
AF	JST Connector SXH-001T-P0.6 or SXH-002T-P0.6	AWG Wire # 28 ~ 22 30 ~ 26

Type	Current Rating Amperes	V_{CES} Volts (x 50)
CM	75	12

CM75YE13-12F

TLI-Series (Three Level Inverter) IGBT

75 Amperes/600 Volts

Absolute Maximum Ratings, $T_j = 25^\circ\text{C}$ unless otherwise specified

Ratings	Symbol	CM75YE13-12F	Units
Junction Temperature	T_j	-40 to 150	$^\circ\text{C}$
Storage Temperature	T_{stg}	-40 to 125	$^\circ\text{C}$
Mounting Torque, Main Terminals, M5 Screw (Max.)	–	30	in-lb
Mounting Torque, Mounting Holes, M5 Screw (Max.)	–	30	in-lb
Weight (Typical)	–	800	Grams
Isolation Voltage (Main Terminal to Baseplate, AC 1 min.)	V_{iso}	2500	V_{rms}

Inverter Part

Collector-Emitter Voltage (G-E Short)	V_{CES}	600	Volts
Gate-Emitter Voltage (C-E Short)	V_{GES}	± 20	Volts
Collector Current DC ($T_C = 25^\circ\text{C}$)	I_C	75	Amperes
Peak Collector Current (Pulse) ^{*2}	I_{CM}	150	Amperes
Emitter Current ($T_C = 25^\circ\text{C}$)	I_E^{*1}	75	Amperes
Peak Emitter Current (Pulse) ^{*2}	I_{EM}^{*1}	150	Amperes
Maximum Collector Dissipation ($T_C' = 25^\circ\text{C}$)	P_C^{*3}	270	Watts

Clamp Diode Part

Repetitive Peak Reverse Voltage	V_{RRM}	600	Volts
Forward Current ($T_C = 25^\circ\text{C}$)	I_{FM}	75	Amperes

Brake Part

Collector-Emitter Voltage (G-E Short)	V_{CES}	1200	Volts
Gate-Emitter Voltage (C-E Short)	V_{GES}	± 20	Volts
Collector Current DC ($T_C = 25^\circ\text{C}$)	I_C	25	Amperes
Peak Collector Current (Pulse) ^{*2}	I_{CM}	50	Amperes
Maximum Collector Dissipation ($T_C' = 25^\circ\text{C}$)	P_C^{*3}	280	Watts
Repetitive Peak Reverse Voltage	V_{RRM}	1200	Volts
Forward Current ($T_C = 25^\circ\text{C}$)	I_{FM}	25	Amperes

*1 I_E , I_{EM} , V_{EC} , t_{rr} , and Q_{rr} represent characteristics of the anti-parallel, emitter-to-collector free-wheel diode (FWDi).

*2 Pulse width and repetition rate should be such that device junction temperature (T_j) does not exceed $T_{j(max)}$ rating.

*3 Junction temperature (T_j) should not increase beyond 150°C .

CM75YE13-12F

TLI-Series (Three Level Inverter) IGBT

75 Amperes/600 Volts

Electrical Characteristics, $T_j = 25^\circ\text{C}$ unless otherwise specified

Characteristics	Symbol	Test Conditions	Min.	Typ.	Max.	Units
Inverter Part						
Collector-Cutoff Current	I_{CES}	$V_{CE} = V_{CES}, V_{GE} = 0V$	–	–	1	mA
Gate-Emitter Threshold Voltage	$V_{GE(th)}$	$I_C = 7.5\text{mA}, V_{CE} = 10V$	5	6	7	Volts
Gate Leakage Current	I_{GES}	$V_{GE} = V_{GES}, V_{CE} = 0V$	–	–	20	μA
Collector-Emitter Saturation Voltage	$V_{CE(sat)}$	$I_C = 75A, V_{GE} = 15V, T_j = 25^\circ\text{C}$	–	1.6	2.2	Volts
		$I_C = 75A, V_{GE} = 15V, T_j = 125^\circ\text{C}$	–	1.6	–	Volts
Input Capacitance	C_{ies}		–	–	20	nF
Output Capacitance	C_{oes}	$V_{CE} = 10V, V_{GE} = 0V$	–	–	1.4	nF
Reverse Transfer Capacitance	C_{res}		–	–	0.75	nF
Total Gate Charge	Q_G	$V_{CC} = 300V, I_C = 75A, V_{GE} = 15V$	–	465	–	nC
Turn-on Delay Time	$t_{d(on)}$	$V_{CC} = 300V, I_C = 75A,$	–	–	450	ns
Turn-on Rise Time	t_r	$V_{GE1} = V_{GE2} = 15V,$	–	–	200	ns
Turn-off Delay Time	$t_{d(off)}$	$R_G = 25\Omega,$	–	–	800	ns
Turn-off Fall Time	t_f	Inductive Load Switching Operation,	–	–	300	ns
Reverse Recovery Time	t_{rr}^{*1}	$I_E = 75A$	–	–	200	ns
Reverse Recovery Charge	Q_{rr}^{*1}		–	0.68	–	μC
Emitter-Collector Voltage	V_{EC}^{*1}	$I_E = 75A, V_{GE} = 0V$	–	–	2.8	Volts
External Gate Resistance	R_G		25	–	83	Ω

Clamp Diode Part

Repetitive Reverse Current	I_{RRM}	$V_R = V_{RRM}$	–	–	1	mA
Forward Voltage Drop	V_{FM}	$I_F = 75A$	–	–	2.8	Volts
Reverse Recovery Time	t_{rr}	$I_F = 75A, V_{CC} = 300V,$	–	–	200	ns
Reverse Recovery Charge	Q_{rr}	$V_{GE1} = V_{GE2} = 15V, R_G = 25\Omega,$ Inductive Load Switching Operation	–	0.68	–	μC

*1 $I_E, I_{EM}, V_{EC}, t_{rr},$ and Q_{rr} represent characteristics of the anti-parallel, emitter-to-collector free-wheel diode (FWDi).



Powerex, Inc., 173 Pavilion Lane, Youngwood, Pennsylvania 15697 (724) 925-7272 www.pwr.com

CM75YE13-12F

TLI-Series (Three Level Inverter) IGBT

75 Amperes/600 Volts

Electrical Characteristics, $T_j = 25^\circ\text{C}$ unless otherwise specified

Characteristics	Symbol	Test Conditions	Min.	Typ.	Max.	Units
Brake Part						
Collector-Cutoff Current	I_{CES}	$V_{CE} = V_{CES}, V_{GE} = 0V$	–	–	1	mA
Gate-Emitter Threshold Voltage	$V_{GE(th)}$	$I_C = 2.5\text{mA}, V_{CE} = 10V$	4.5	6	7.5	Volts
Gate Leakage Current	I_{GES}	$V_{GE} = V_{GES}, V_{CE} = 0V$	–	–	0.5	μA
Collector-Emitter Saturation Voltage	$V_{CE(sat)}$	$I_C = 25A, V_{GE} = 15V, T_j = 25^\circ\text{C}$	–	2.7	3.4	Volts
		$I_C = 25A, V_{GE} = 15V, T_j = 125^\circ\text{C}$	–	2.45	–	Volts
Input Capacitance	C_{ies}		–	–	5.0	nF
Output Capacitance	C_{oes}	$V_{CE} = 10V, V_{GE} = 0V$	–	–	1.8	nF
Reverse Transfer Capacitance	C_{res}		–	–	1.0	nF
Total Gate Charge	Q_G	$V_{CC} = 600V, I_C = 25A, V_{GE} = 15V$	–	125	–	nC
Turn-on Delay Time	$t_{d(on)}$	$V_{CC} = 600V, I_C = 25A,$	–	–	150	ns
Turn-on Rise Time	t_r	$V_{GE1} = V_{GE2} = 15V,$	–	–	150	ns
Turn-off Delay Time	$t_{d(off)}$	$R_G = 25\Omega,$	–	–	350	ns
Turn-off Fall Time	t_f	Inductive Load Switching Operation,	–	–	400	ns
Reverse Recovery Time	t_{rr}^{*1}	$I_E = 25A$	–	–	250	ns
Reverse Recovery Charge	Q_{rr}^{*1}		–	1.1	–	μC
Forward Voltage Drop	V_{FM}	$I_F = 25A$	–	–	3.5	Volts

Thermal and Mechanical Characteristics, $T_j = 25^\circ\text{C}$ unless otherwise specified

Characteristics	Symbol	Test Conditions	Min.	Typ.	Max.	Units
Thermal Resistance, Junction to Case ^{*4}	$R_{th(j-c)Q}$	Inverter Part, IGBT	–	–	0.46	$^\circ\text{C/W}$
Thermal Resistance, Junction to Case ^{*4}	$R_{th(j-c)D}$	Inverter Part, FWDi	–	–	0.71	$^\circ\text{C/W}$
Thermal Resistance, Junction to Case ^{*4}	$R_{th(j-c)D}$	Clamp Diode Part	–	–	0.71	$^\circ\text{C/W}$
Thermal Resistance, Junction to Case ^{*4}	$R_{th(j-c)Q}$	Brake Part, IGBT	–	–	0.44	$^\circ\text{C/W}$
Thermal Resistance, Junction to Case ^{*4}	$R_{th(j-c)D}$	Brake Part, Clamp Diode	–	–	0.83	$^\circ\text{C/W}$
Contact Thermal Resistance ^{*4*5}	$R_{th(c-f)}$	Thermal Grease Applied (Per 1 Module)	–	0.012	–	$^\circ\text{C/W}$

*1 $I_E, I_{EM}, V_{EC}, t_{rr}$, and Q_{rr} represent characteristics of the anti-parallel, emitter-to-collector free-wheel diode (FWDi).

*4 T_C measured point is just under the chips. If using this value, $R_{th(f-a)}$ should be measured just under the chips.

*5 Typical value is measured by using thermally conductive grease of $\lambda = 0.9 \text{ [W/(m} \cdot \text{K)]}$.

CM75YE13-12F
TLI-Series (Three Level Inverter) IGBT
 75 Amperes/600 Volts

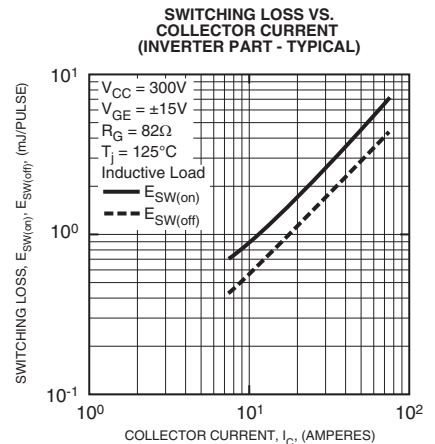
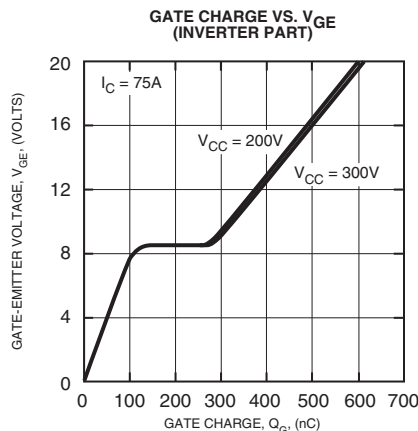
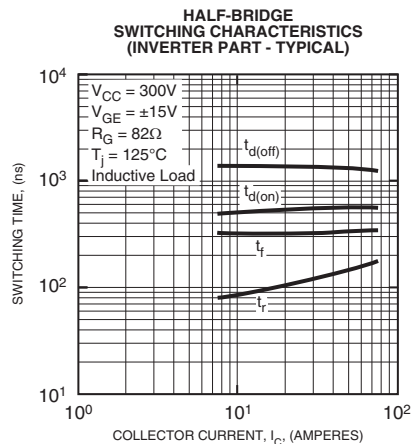
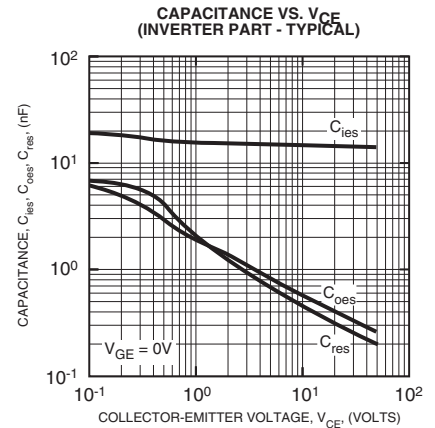
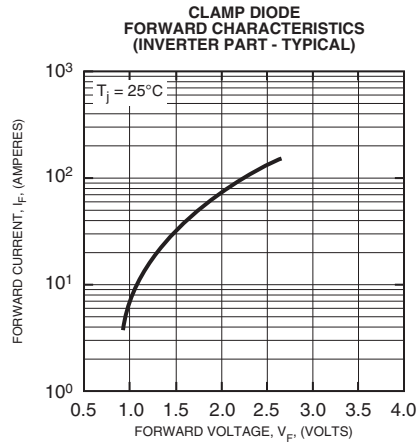
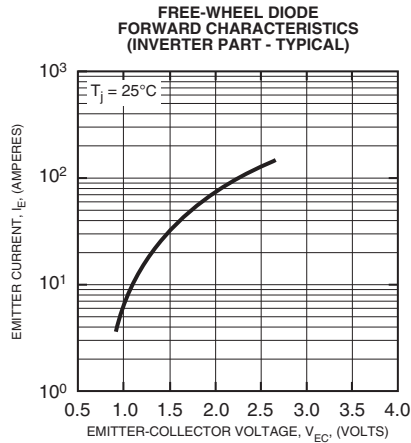
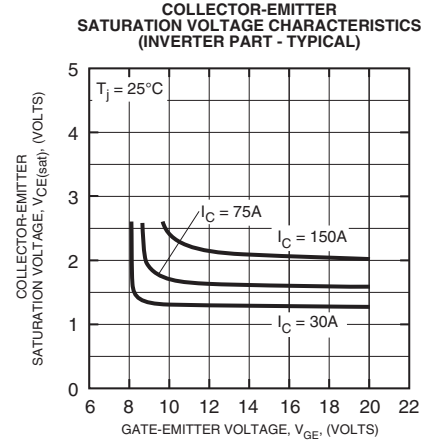
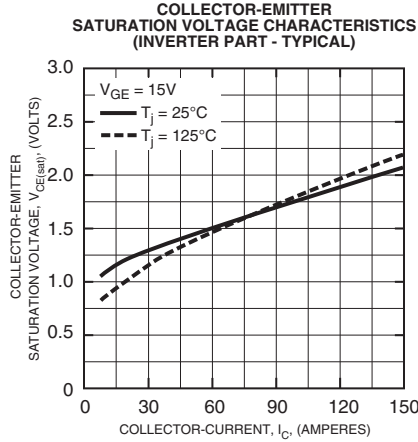
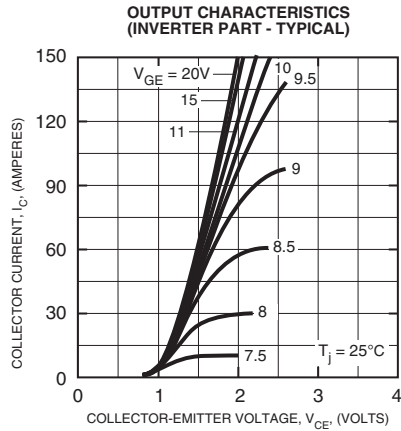

CM75YE13-12F

TLI-Series (Three Level Inverter) IGBT

75 Amperes/600 Volts

REVERSE RECOVERY SWITCHING LOSS VS. FORWARD CURRENT (CLAMP DIODE PART - TYPICAL)

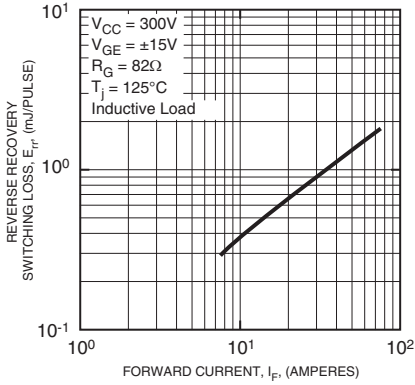

TRANSIENT THERMAL IMPEDANCE CHARACTERISTICS (TYPICAL)

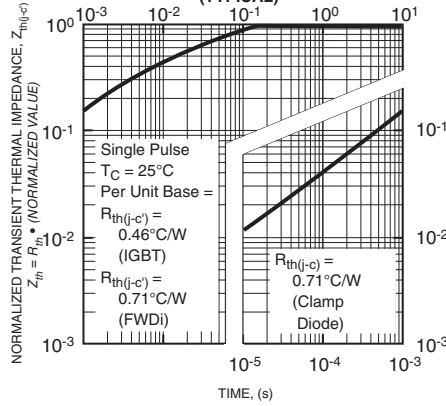

COLLECTOR-EMITTER SATURATION VOLTAGE CHARACTERISTICS (BRAKE PART - TYPICAL)

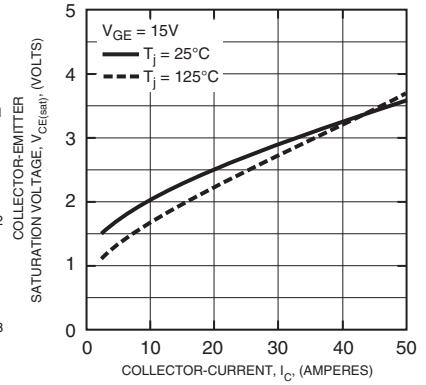

FREE-WHEEL DIODE FORWARD CHARACTERISTICS (BRAKE PART - TYPICAL)

